

SPECIFICATIONS

WiNG^{NT}

GENERAL		
	AFU	DFU
Acquisition	<ul style="list-style-type: none"> Data filtering, compression & time stamping 24 bits A/D conversion 	<ul style="list-style-type: none"> Data filtering, compression & time stamping 24 bits data
Sensor tests	resistance, noise, tilt	distortion, noise, tilt
Instrument tests	noise, gain, phase, distortion	gain, phase, distortion
Memory autonomy	1480 hours (60 days 24 hr/day)	
Battery autonomy (Pathfinder enabled) (Pathfinder disabled)	> 960 hours (40 days 24 hr/7days) > 1200 hours (50 days 24 hr/7days)	
Weight	760 g	780 g (no spike), 830 g (with spike)

ENVIRONMENTAL LIMITS	
Operational temperature	-40 °C to +60 °C
Storage temperature	-40 °C to +60 °C
Ingress protection	IP68
Battery charge temperature	0 °C to +30 °C

RADIO TRANSMISSION -Pathfinder	
Frequency band	2402 MHz – 2478 MHz
Range	75 m nominal LOS

RADIO TRANSMISSION - Direct	
Frequency band	2402 MHz – 2478 MHz
Range	50 m nominal LOS

GNSS	
Supported constellations	GPS L1 C/A / SBAS / QZSS, GLONASS, BeiDou, Galileo
Cold start acquisition sensitivity	GPS, GLONASS: -148 dBm



SENSOR PARAMETERS

	AFU	DFU
Sensor type	External	MEMS Accelerometer
Sample rate	4, 2, 1, 0.5 ms	
Timing accuracy	Synchronous to gps clock < +/-5 μ s	
Input impedance differential mode	20 k Ω // 77 nF	-
Bandwidth	-	0-400 Hz, 3 dB
Low-cut filter	Selectable (none, 0.15625 Hz, 0.3125 Hz, 0.625 Hz, 1.25 Hz, 2.5 Hz)	
High-cut filter	0.8 FN linear or minimum phase	
Full scale	1.6 V RMS (0 dB), 400 mV RMS (12 dB), 100 mV RMS (24 dB) (pre-amp gain)	5 m/s ² (510 mg)
Noise (3-200Hz)	350 nV RMS(0 dB), 145 nV RMS (12 dB), 90 nV RMS (24 dB)	-
Noise (10-200Hz)	-	0.15 μ m/s ² /√Hz (15 ng/√Hz)
Instantaneous dynamic range	132 dB	128 dB
System dynamic range	145 dB	-
Distortion	-110 dB	-90 dB
Gain accuracy	< 0.1 %	< 0.25 %
Phase accuracy	< 20 μ s	< 5 μ s

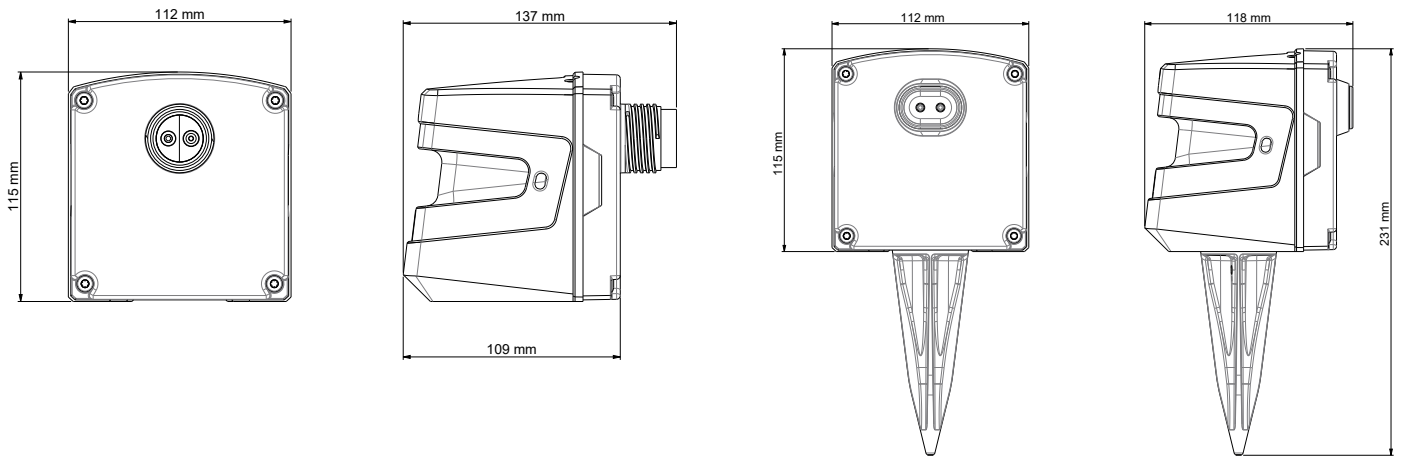

RACK

Dimensions	2075 mm H x 600 mm W x 300 mm D without shock absorbers 2200 mm H x 600 mm W x 630 mm D with shock absorbers and screen
Weight	130 Kg
Capacity	36 DFU
Charging time	6 hr (fully discharged – fully charged)
Input voltage	110-240 Vac
Rated power	950 W (with 36xDFU charging)
Operational temperature	0 °C to +30 °C
Storage temperature	-40 °C to +70 °C
Charge temperature	0 °C to +30 °C
Protection rating	IP4X

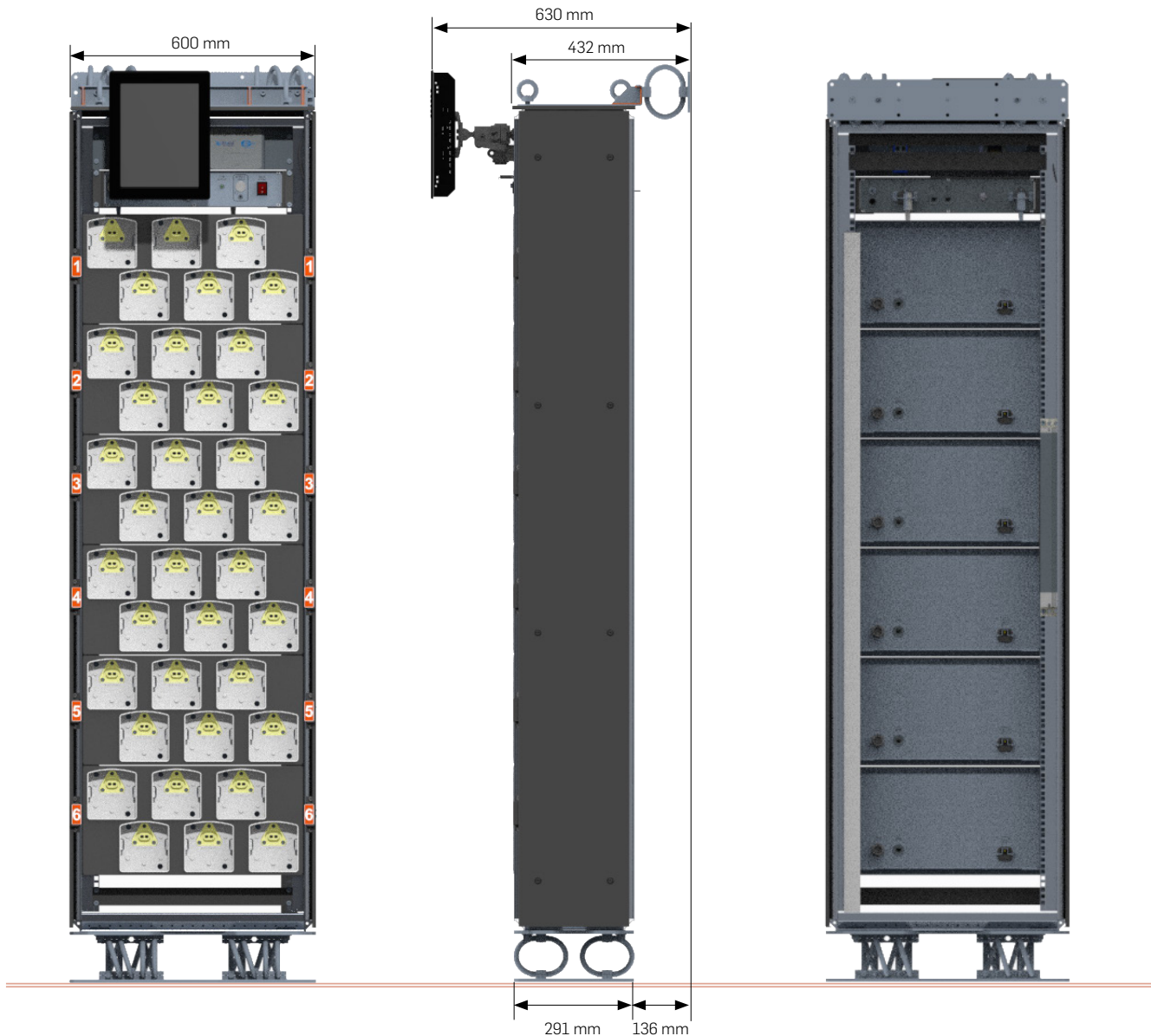

PORTABLE HARVESTER CHARGER

Dimensions	682x777x771 mm
Weight	65 Kg
Capacity	12 slots
Charging time	6 hr (fully discharged – fully charged)
Input voltage	110-240 Vac
Rated power	325 W (with 12xDFU charging)
Operational temperature	0 °C to +30 °C
Storage temperature	-40 °C to +70 °C
Charge temperature	0 °C to +30 °C
Protection rating	IP54 closed / IP4X open

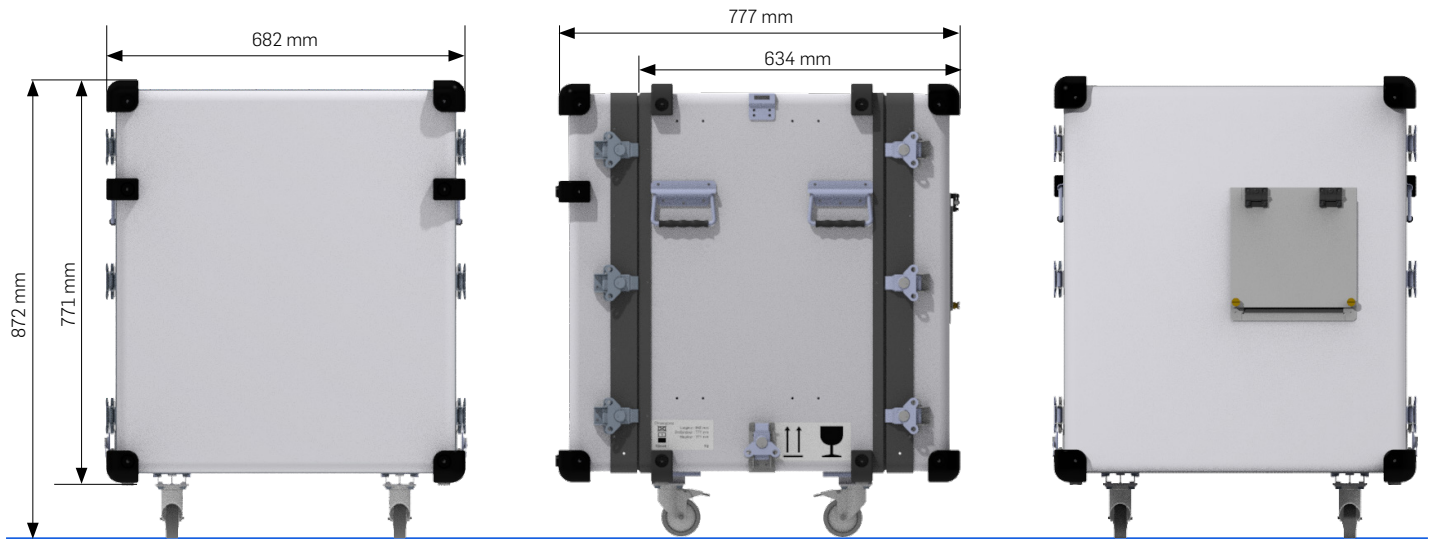

System architecture: WiNG

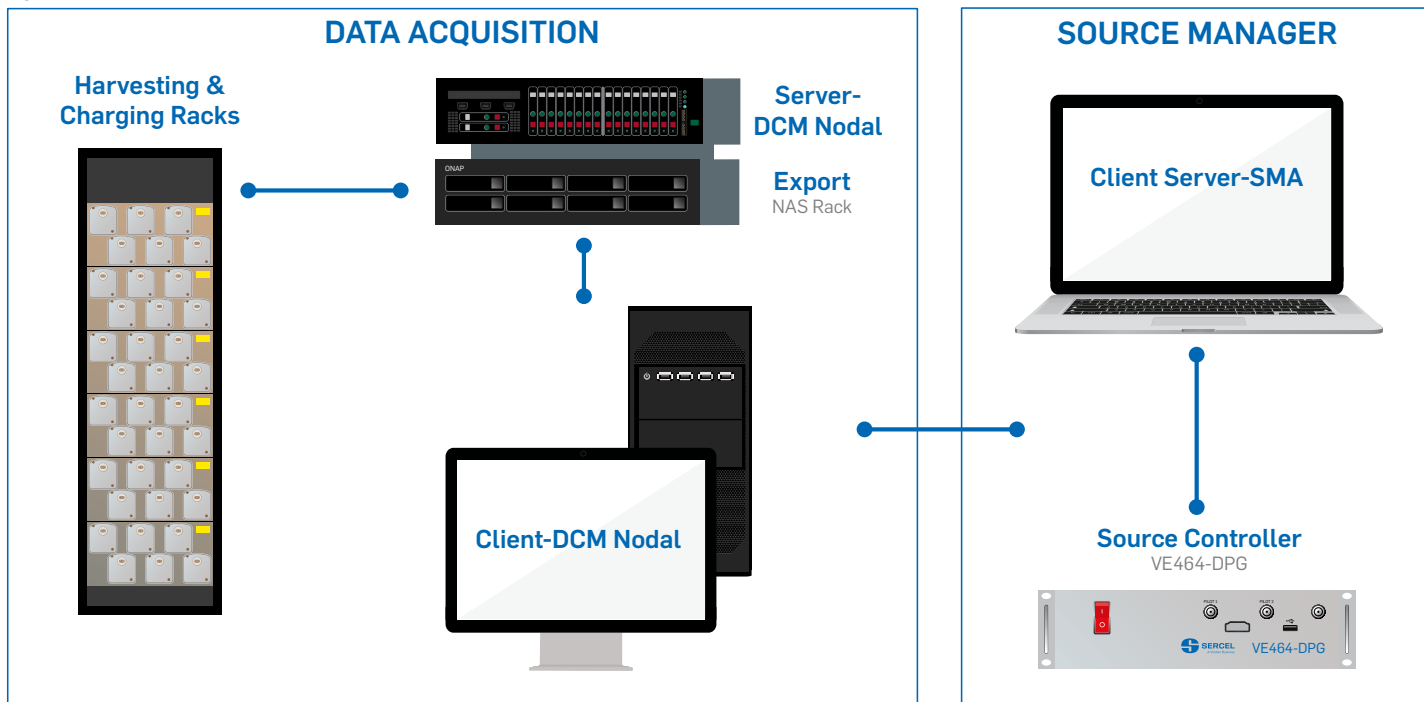

System architecture: WiNG Lite

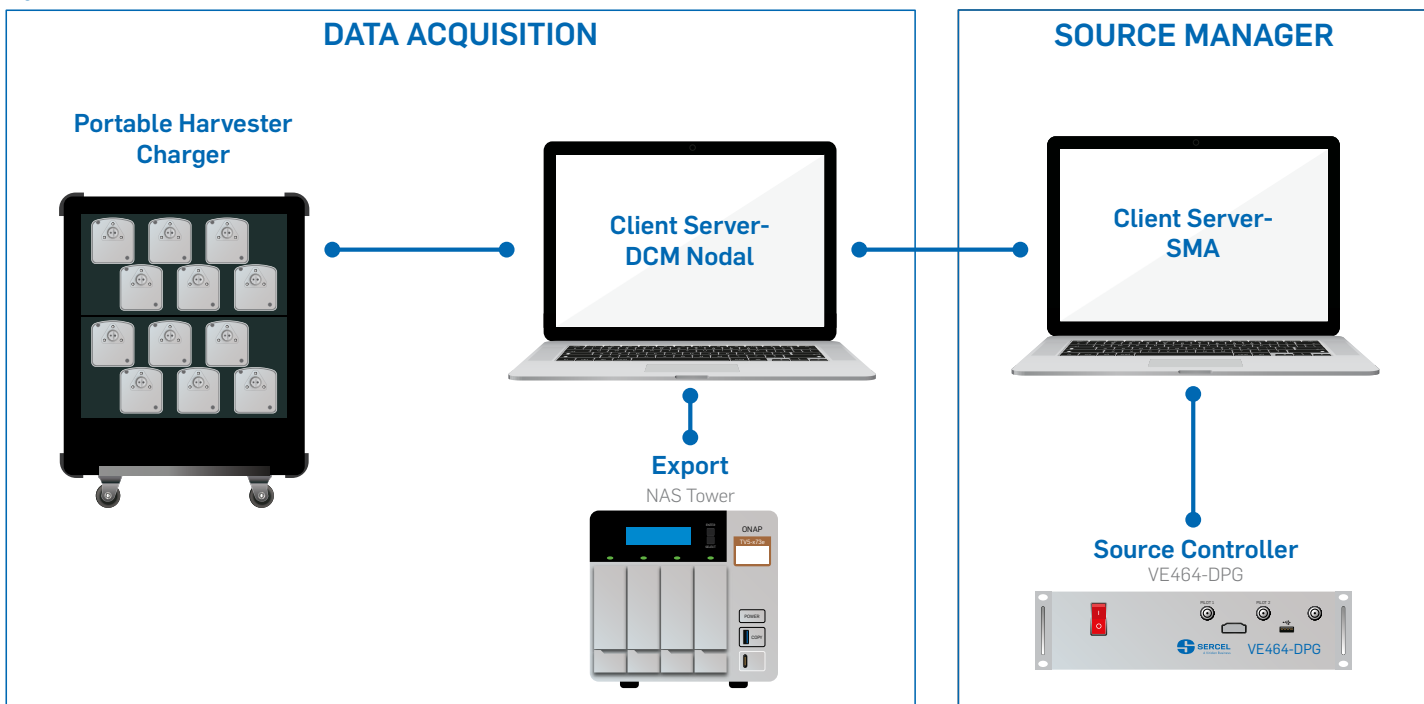

FIELD MONITOR

FIELD MONITOR BOX

Dimensions	152 mm (6") x 110 mm (4.33") x 47 mm (1.85")
Weight	565 g
Charging time	3 hrs (fully discharged – fully charged)
Input voltage	5 V (USB) – (230 Vac / 5 V 2 A for USB Charger)
Radio GFSK	Direct Frequency band 2402 MHz – 2478 MHz
WIFI	2.4 GHz : 802.11 g 5 GHz : 802.11 an
Operational temperature	-20 °C to +60 °C
Storage temperature	-40 °C to +60 °C
Charge temperature	0 °C to +30 °C
Protection rating	IP67
Battery autonomy	Up to 10 h

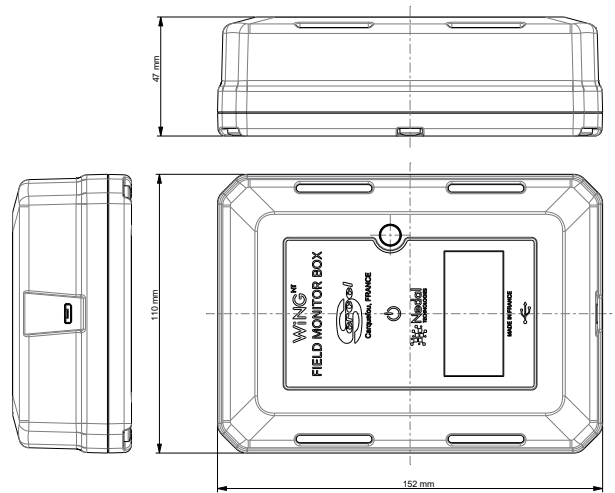

FIELD MONITOR DEVICE

Type	Phablet 8"
Dimensions	210 mm (8.3") x 124.4 mm (4.9") x 8.0 mm (0.31")
Weight	345 g
Protection rating	IP68
Battery autonomy	Up to 10 h

Note: Sercel reserves the right to change its specifications without prior notice.
All specifications are typical at 25 °C, 2 ms sampling except where otherwise stated

SERCEL - FRANCE

16 rue de Bel Air - B.P. 30439 - 44474 CARQUEFOU Cedex
Téléphone : (33) 2 40 30 11 81
E-mail : sales.nantes@sercel.com
SAS au capital de 25 000 000 €
Siège Social : 16 rue de Bel Air - 44470 CARQUEFOU
378.040.497 R.C.S. Nantes Code APE 2651B

SERCEL INC. - U.S.A.

17300 Park Row
Houston, Texas 77084
Telephone : (1) 281 492 6688
E-mail : sales.houston@sercel.com

sercel.com